

# PRESS AUTOMATION

The leading supplier for large tandem presses

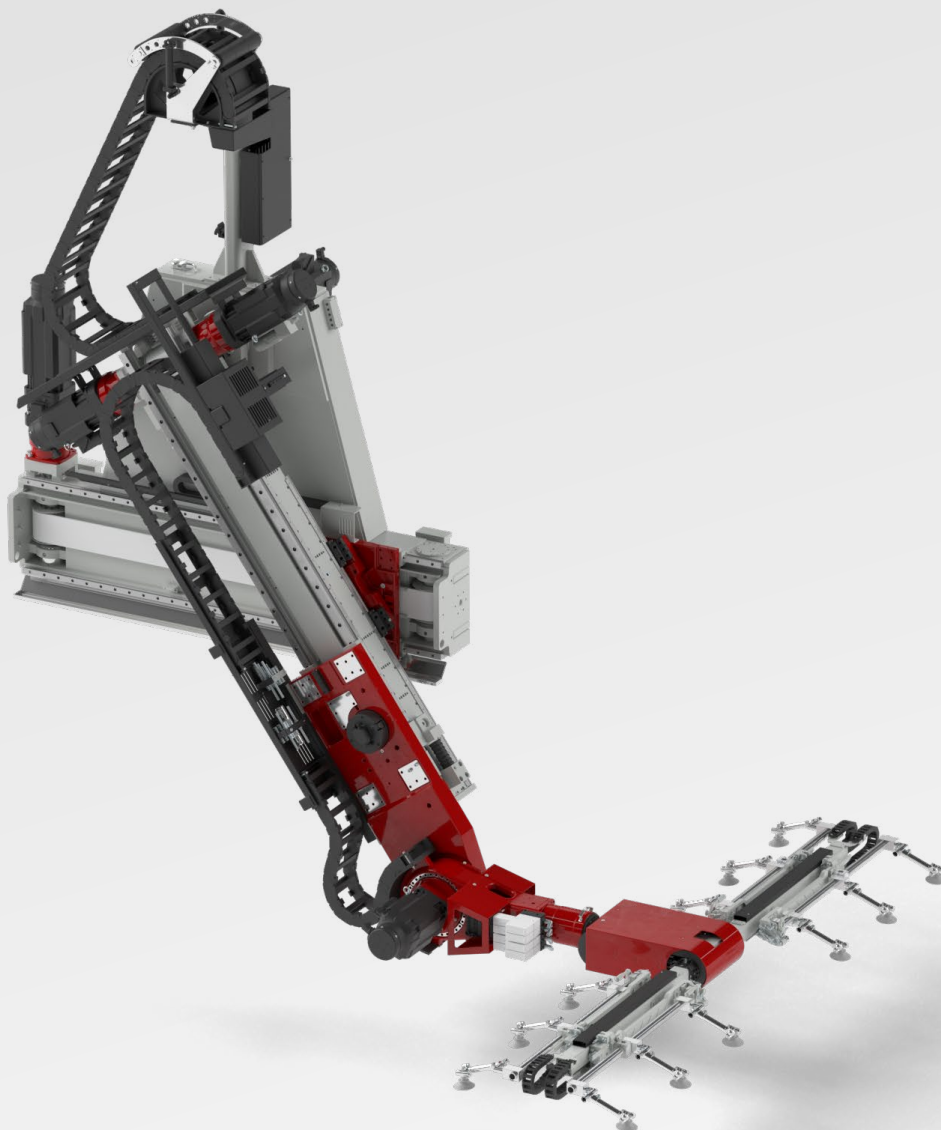

TECHNICAL EXCELLENCE

HIGH EFFICIENCY

PRODUCTION AVAILABILITY

## TECHNICAL EXCELLENCE

The company Güdel offers ultra-modern automation solutions that are particularly well-suited for companies that require a high level of availability and output rates in their production. With over 70 years of experience and the successful automation of more than 200 press lines globally, Güdel is a leading supplier in this sector.

The modular automation systems from Güdel are characterized by their ability to achieve extremely high output rates of up to 21 strokes per minute. This flexibility is especially evident in solutions for Front of Line, Interpress and End of Line solutions.

The Front of Line system from Güdel offers you the ability to efficiently stack, steel and aluminum blanks. The patented pre-separation technology makes it possible to process aluminum blanks without productivity loss. The patented positioning unit requires no additional tools and makes it possible to center up to four blanks at the same time.

For the Interpress automation, Güdel provides both single and double-arm solutions that are tailored to your specific requirements. These systems can be integrated both in mechanical and servo presses, which enhances their flexibility and possible applications even further.

The End of Line solutions from Güdel are also modular and can be scaled as needed. This makes it possible to adjust the systems to the specific requirements of your production, no matter whether it is for new systems or modernizing existing systems (retrofits).

With Güdel you get not only a solution, but a high-availability, high-performance and flexible automation system that makes your production more efficient and more reliable.

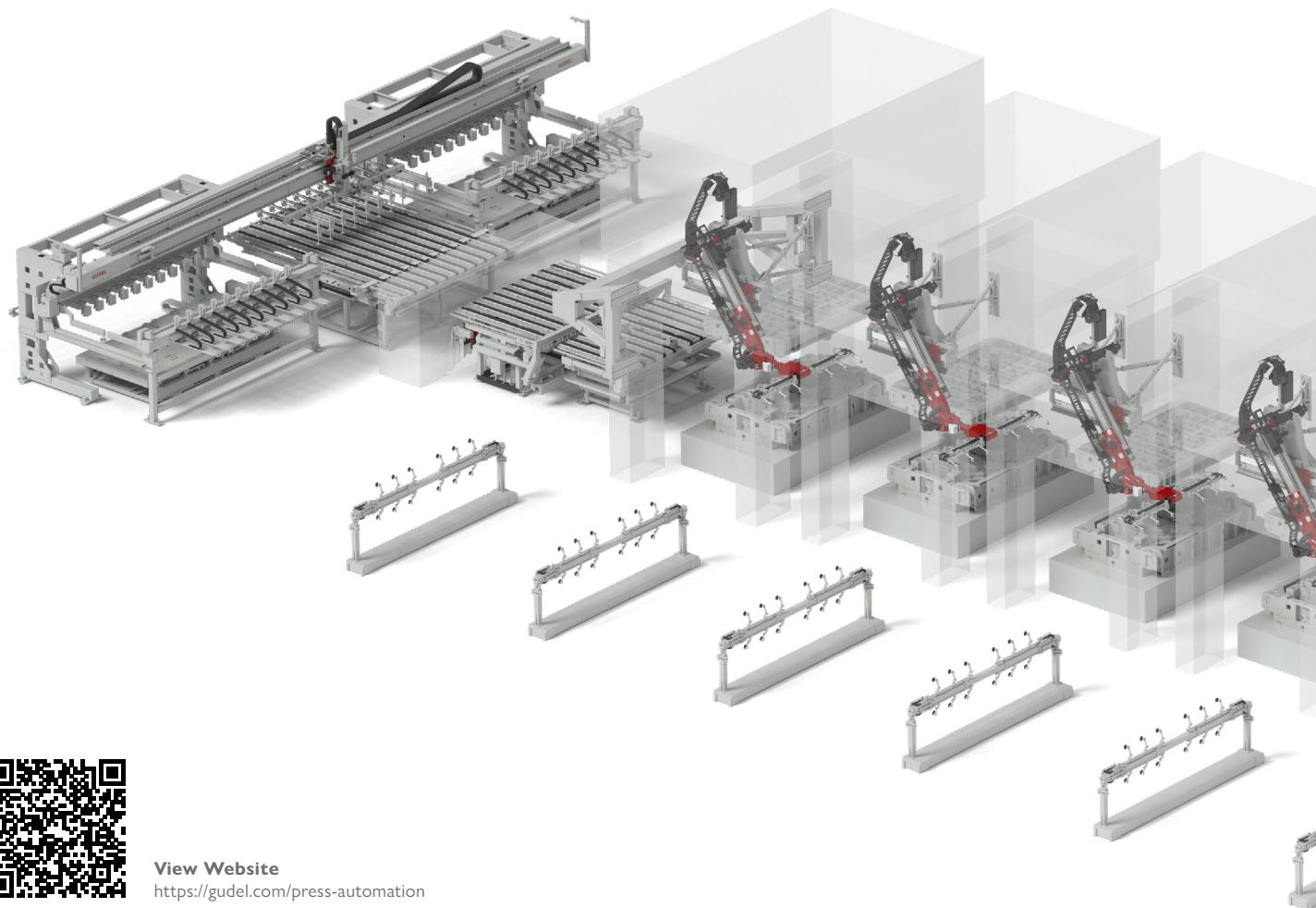

**View Website**  
<https://gudel.com/press-automation>

## HIGH EFFICIENCY

With the Güdel Front of Line system, you can completely do away with tooling changes. Thanks to the patented universal tooling, no change toolings are required for the gantry, and even our centering station can be used without additional tools. This saves valuable storage space and resources, thereby significantly reducing your costs.

The patented Güdel Motion Designer offers you a powerful tool you can use to simulate and optimize your press line's movements offline. You can check the free movement and potential collisions already in advance, which saves you valuable time when starting up the system. Moreover, the Motion Designer allows you to optimize the utilization and efficiency of the entire production facility.

Our experts continuously develop and optimize the systems further to ensure that we not only meet your requirements, but also exceed the increasing expectations in the industry. This allows you to meet your goals efficiently and reliably.

## PRODUCTION AVAILABILITY

Improve the output rates and the available operating time of your system with an automation system from Güdel. The press automation concept was developed by our experts based on many years of experience and while using modern calculation tools so that it meets the many complex requirements of a press automation system.

Based on tried-and-true standard components, you get a robust mechanism with modern control and drive technologies (Beckhoff TwinCAT 3 or Siemens TIA-gantry). Thanks to the high level of in-house production depth, the modular design as well the many years of experience, you get an optimally coordinated system.

Our service provides you an offer tailored to your needs throughout the entire life cycle of the automation. We guarantee you expert support with our subsidiaries worldwide. Our automation systems are characterized by low maintenance costs.

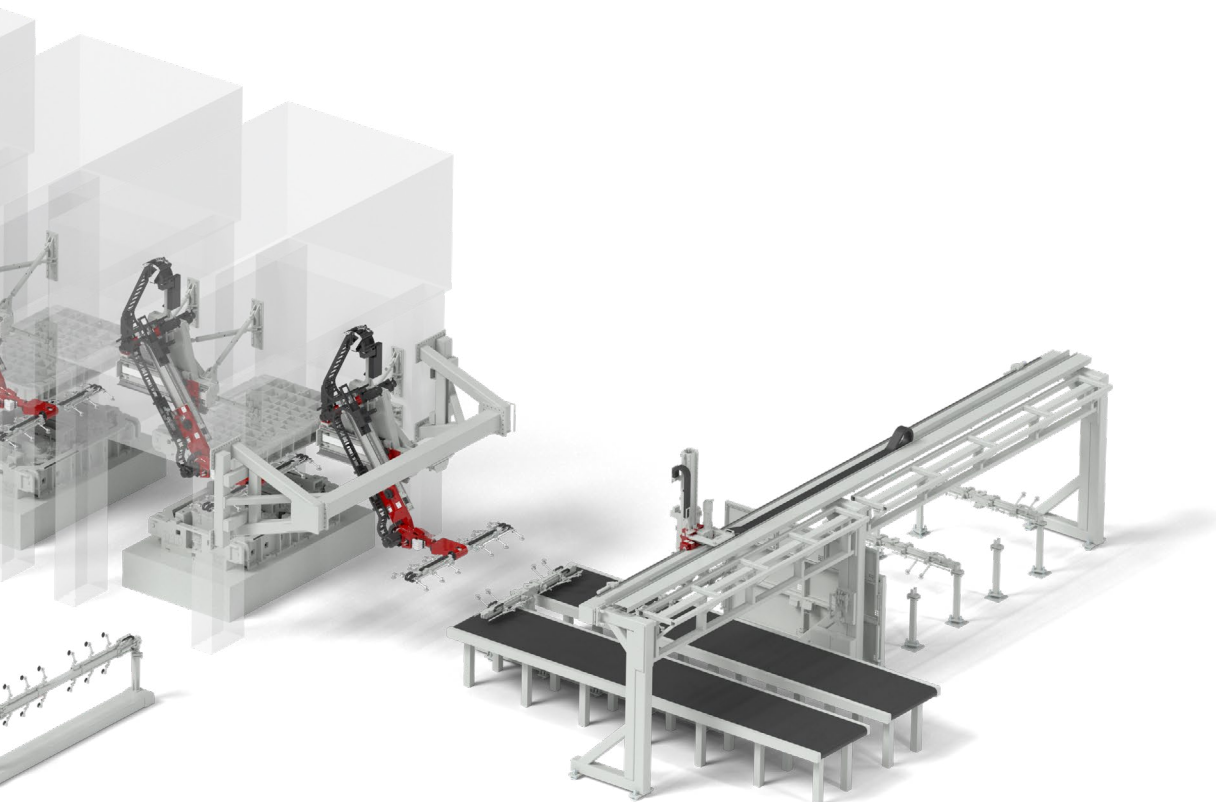

Globally present – Güdel manufactures in its own plants in order to guarantee high quality in line with Swiss standards.

We are your expert partner throughout the entire life cycle of the automation system, including analysis and conversions (retrofits).

Not only do we offer solutions for the automation of tandem presses, but also solutions for the automation of transfer presses.

We stay on the ball for you in a world with rapidly changing technologies. With a solution from Güdel, you get a high-performance, reliable system that helps you reach your goals (OEE).

We look forward to being your innovative and reliable automation partner.

Güdel Group AG  
Gaswerkstrasse 26  
4900 Langenthal  
Switzerland  
+41 62 916 91 91  
info@ch.gudel.com

We are here to help you. Worldwide.

